

Clearly Different. Clearly Innovative.



Victory Brewery
Parkesburg, Pennsylvania
ARCHITECT
Bernardon Haber Holloway Architects, Kennett Square, Pennsylvania
GLAZING CONTRACTOR
Zephyr Aluminum, Lancaster, Pennsylvania
PHOTOGRAPHER
© Perzel Photography Group

Today, a growing number of architects are designing buildings with sleek, uninterrupted all-glass façades. Clearwall™ Curtain Wall, an innovative 4-sided toggle glazed (TG) system*, delivers this highly desired aesthetic for low-rise applications. Clearwall™ Curtain Wall strikes a balance of form and function through its groundbreaking toggle design, which reduces installation labor, simplifies on-site logistics and enhances safety while providing superior aesthetics. Featuring inspired design, tight construction and brilliant results, Clearwall™ Curtain Wall is clearly different and clearly innovative.

AESTHETICS

Now designers have a clear option when they want an admired monolithic look for low-rise applications. Kawneer's Clearwall™ Curtain Wall, an outside glazed system, achieves the desired appearance of a 4-sided structural silicone glazed (SSG) system using a unique toggle assembly that directly captures glass. And because it was developed specifically with low-rise commercial and institutional building applications in mind, Clearwall™ Curtain Wall provides the same aesthetic as 4-sided SSG, point-supported glass or unitized curtain wall systems at a fraction of the cost. The innovative curtain wall system also features various mullion depths for increased design flexibility based on project requirements.

* Multiple patents pending

FABRICATION AND INSTALLATION

Clearwall™ Curtain Wall's greatest efficiency is achieved by eliminating the field application of structural silicone and its associated cure times. During glazing, toggle assemblies mechanically capture the inboard lite of adjacent recessed spacer insulating glass units. Other glazing options allow toggles to capture a metal interface attached to a regular insulating glass unit. Additionally, straight cuts without notching simplify fabrication, while screw spline construction allows frames to be pre-assembled in the shop and shipped ready to glaze to the job site, reducing on-site handling and labor time. Shear block construction is also available with deeper mullions and optional steel reinforcement for higher free span applications.

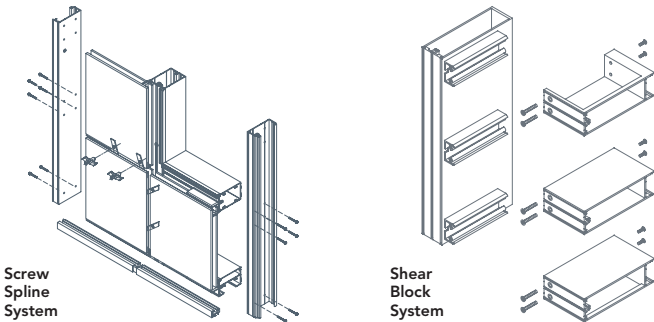

Screw Spline System

Shear Block System

Clearwall™ Curtain Wall offers three toggle glazed (TG) options (Screw Spline System shown)

1. Clearwall™ SS (Screw Spline) or SB (Shear Block): In this standard glazing option, toggles capture the inboard lite of 1-1/8" recessed spacer insulating glass units†. This combination completely eliminates the use of any structural silicone, thereby saving costly application and cure times.

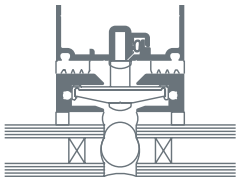
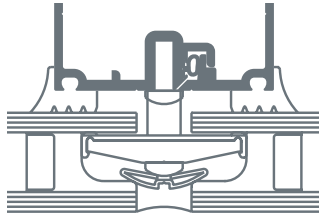

2. Clearwall™ SSI (Screw Spline Interface) or SBI (Shear Block Interface): In this glazing option, toggles capture a metal interface, which is shop-applied to standard 1" insulating glass with structural silicone.

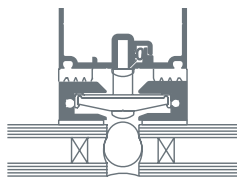

3. Clearwall™ SSIT (Screw Spline Interface Tape) or SBIT (Shear Block Interface Tape): In this glazing option, toggles capture a metal interface, which is shop-applied to standard 1" insulating glass with 3M™ VHB™ Structural Glazing Tape (SGT)††.

† Recessed spacer by qualified glass supplier
 †† 3M and VHB are trademarks of 3M Company



PERFORMANCE

For enhanced energy efficiency, the system accommodates 1-1/8" and 1" insulating or laminated glass, which provides increased thermal performance and enhances STC and OITC (sound resistance) performance. Clearwall™ Curtain Wall has been tested in accordance with North American performance standards, including seismic, thermal cycling and dynamic water. Additionally, Clearwall™ Curtain Wall has been third-party tested for for both large and small missile impact to withstand windborne debris and hurricane forces.

PERFORMANCE TEST STANDARDS

| | |
|---|------------------------------|
| Air Infiltration | ASTM E283 |
| Water – Static | ASTM E331 |
| Water – Dynamic | AAMA 501.1, 520 |
| Structural – Uniform wind load | ASTM E330; TAS 202 |
| Thermal Cycling | AAMA 501.5 |
| Thermal Transmittance – U factor | AAMA 1503, 507; NFRC 100 |
| Condensation Resistance (CRF, I, CR) | AAMA 1503; CSA 440; NFRC 500 |
| Overall Solar Heat Gain Coefficient (SHGC & VT) | NFRC 200; AAMA 507 |
| Sound Transmission Class (STC, OITC) | ASTM E90, E1425 |
| Seismic | AAMA 501.4 |

FOR THE FINISHING TOUCH

Architectural Class I anodized aluminum finishes are available in clear and Permanodic™ color choices.

Painted finishes, including fluoropolymer, that meet AAMA 2605 are offered in many standard choices and an unlimited number of specially designed colors.

Solvent-free powder coatings add the green element with high performance, durability and scratch resistance that meet the standards of AAMA 2604.

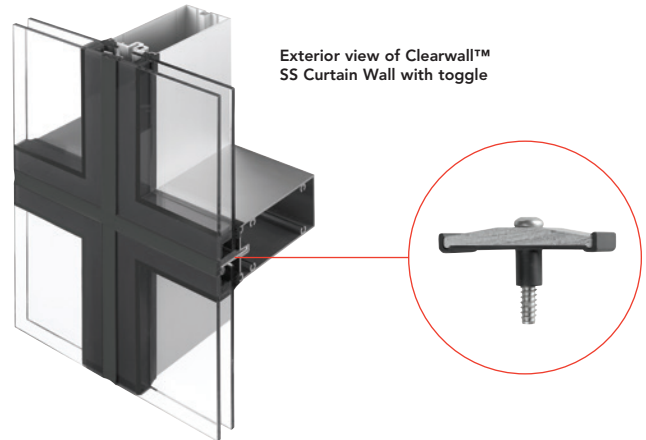

Exterior view of Clearwall™ SS Curtain Wall with toggle